

INSTRUCTION SHEET

MOTORCRAFT CARBURETOR - MODEL 2100-D

50-731

GENERAL EXPLODED VIEW

THE GENERAL DESIGN AND PARTS SHOWN WILL VARY TO INDIVIDUAL UNITS COVERED ON THIS INSTRUCTION SHEET

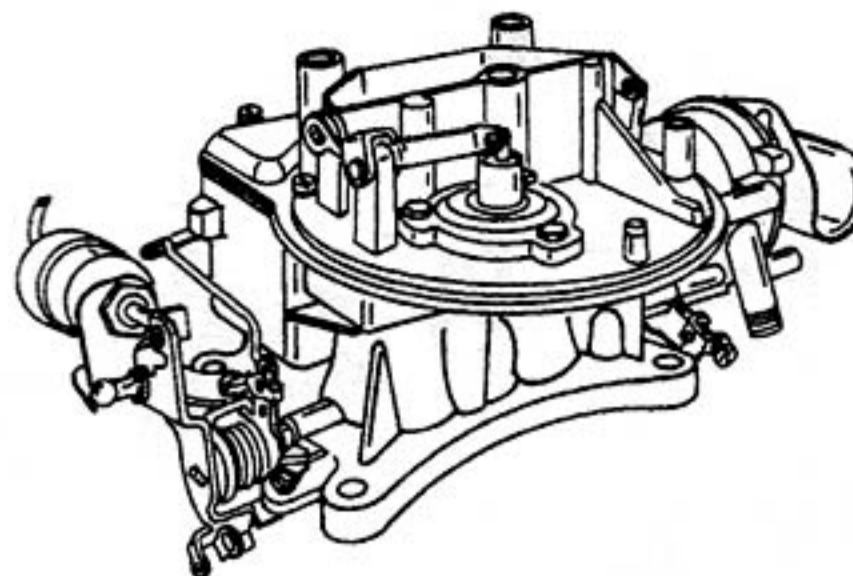

DISASSEMBLY

USE EXPLODED VIEW AS A GUIDE. THE NUMERICAL SEQUENCE MAY GENERALLY BE FOLLOWED TO DISASSEMBLE UNIT FAR ENOUGH TO PERMIT CLEANING AND INSPECTION. NOTE: TO REMOVE PLASTIC LIMITER CAPS (50) INSTALL A SHEET METAL SCREW IN THE CENTER OF THE CAP AND TURN CLOCKWISE.

NOMENCLATURE

REF. NO.	REF. NO.
1. SCREW & LOCKWASHER - SOLENOID	27. SCREW - PUMP DISCHARGE NOZZLE
2. SOLENOID ASSEMBLY	28. PLATE - AIR DISTRIBUTION
3. PIN-VACUUM BREAK LEVER	29. VENTURI CLUSTER ASSEMBLY
4. LEVER - VACUUM BREAK	30. GASKET - VENTURI CLUSTER ASSEMBLY
5. SCREW (3) - VACUUM BREAK COVER	31. WEIGHT - DISCHARGE CHECK BALL
6. COVER - VACUUM BREAK	32. BALL - DISCHARGE CHECK
7. DIAPHRAGM ASSY.-VACUUM BREAK	33. RETAINER - FLOAT PIN
8. SPRING-DIAPHRAGM RETURN	34. PIN - FLOAT HINGE
9. SCREW & LOCKWASHER-CHOKE ROD LEVER	35. FLOAT & LEVER ASSEMBLY
10. LEVER - CHOKE ROD	36. NEEDLE, SEAT AND GASKET ASSEMBLY
11. SCREW & LOCKWASHER (4) - BOWL COVER	37. JETS - MAIN METERING
12. BOWL COVER ASSEMBLY	38. RETAINER - PUMP ROD
13. GASKET - BOWL COVER	39. PUMP ROD
14. SCREW (3) - STAT CLAMP	40. SCREW (4) - PUMP COVER
15. CLAMP - STAT	41. PUMP COVER & LEVER ASSY.
16. CHOKE COVER & SPRING ASSY.	42. PUMP DIAPHRAGM ASSEMBLY
17. GASKET - STAT COVER	43. SPRING - PUMP DIAPHRAGM RETURN
18. SCREW & LOCKWASHER - AIR SHIELD	44. VALVE - PUMP INLET CHECK
19. AIR SHIELD	45. SCREW & LOCKWASHER (4) - ECONOMIZER VALVE COVER
20. RETAINER - CHOKE ROD	46. COVER - ECONOMIZER VALVE
21. ROD - CHOKE	47. GASKET - ECONOMIZER VALVE COVER
22. SEAL - CHOKE ROD	48. VALVE - ECONOMIZER
23. RETAINER LOWER - FAST IDLE CAM ROD	49. GASKET - ECONOMIZER VALVE
24. SCREW & LOCKWASHER (3) - CHOKE HOUSING ASSEMBLY	50. CAPS - IDLE LIMITER
25. CHOKE HOUSING ASSEMBLY	51. NEEDLE - IDLE ADJUSTING
26. GASKET - CHOKE HOUSING	52. SPRING - IDLE ADJ. NEEDLE
	53. MAIN BODY ASSEMBLY

CLEANING

CLEANING MUST BE DONE WITH CARBURETOR DISASSEMBLED. SOAK PARTS LONG ENOUGH TO SOFTEN AND REMOVE ALL FOREIGN MATERIAL. USE (1) A CARBURETOR CLEANING SOLVENT, (2) LACQUER THINNER OR (3) DENATURATED ALCOHOL. MAKE CERTAIN THE THROTTLE BORES ARE FREE OF ALL CARBON AND VARNISH DEPOSITS. RINSE OFF IN SUITABLE SOLVENT. BLOW OUT ALL PASSAGES IN CASTINGS WITH COMPRESSED AIR AND CHECK CAREFULLY TO INSURE THOROUGH CLEANING OF OBSCURE AREAS.

CAUTION: DO NOT SOAK PARTS CONTAINING RUBBER MATERIALS SUCH AS (2), (7), (28), (35), (42), (44), (48) IN CLEANING SOLVENT.

REASSEMBLY

REASSEMBLE IN REVERSE ORDER OF DISASSEMBLY. NOTE SPECIAL INSTRUCTIONS AND FOLLOW NUMERICAL OUTLINE IN MAKING ADJUSTMENTS NECESSARY FOR CARBURETOR BEING SERVICED.

SPECIAL INSTRUCTIONS

IDLE ADJUSTING NEEDLES (51) - TURN IN UNTIL SEATED, THEN BACK OUT 1 1/2-2 TURNS.

ECONOMIZER VALVE (48) - USE CARE WHEN TIGHTENING TO PREVENT DISTORTION OF GASKET (49).

PUMP INLET CHECK VALVE (44) INSTALLATION. LUBRICATE TIP OF NEW VALVE AND INSERT IN CENTER HOLE OF PUMP CAVITY. USE NEEDLE NOSE PLIERS AND PULL THRU FROM FUEL BOWL SIDE UNTIL FULLY SEATED. CUT OFF VALVE TIP AT RETAINING SHOULDER.

PUMP DIAPHRAGM RETURN SPRING (43) INSTALLATION. INSTALL LARGE OPEN END OF SPRING OVER RUBBER INLET CHECK VALVE (44).

CHOKE COVER (16) INSTALLATION: BE SURE TO INSTALL BI-METAL SPRING HOOK IN SLOT OF LEVER.

CARBURETOR HOLD DOWN NUTS - TORQUE TO 14 FT. LBS.
AIR CLEANER STUD - TORQUE TO 10 FT. LBS.

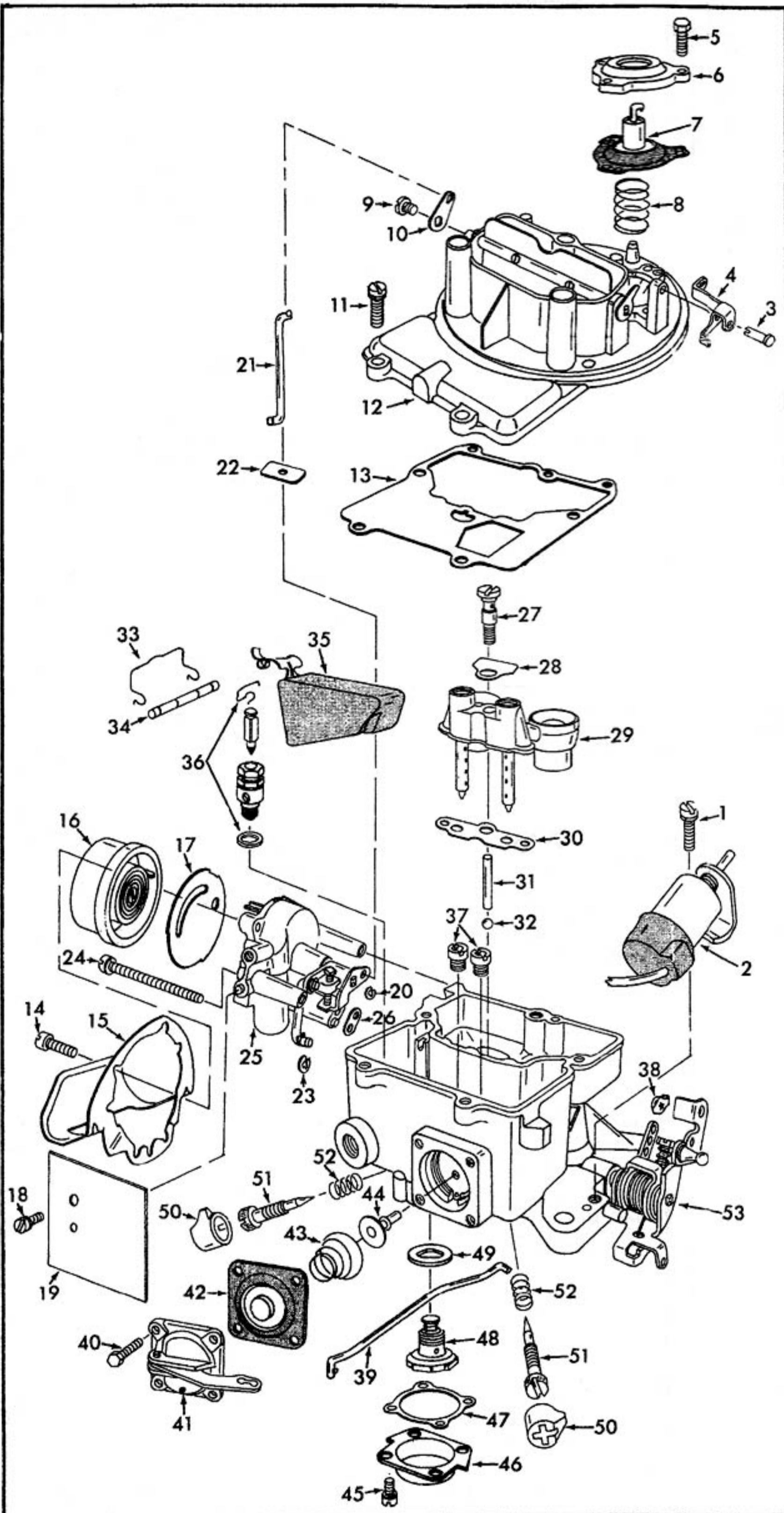

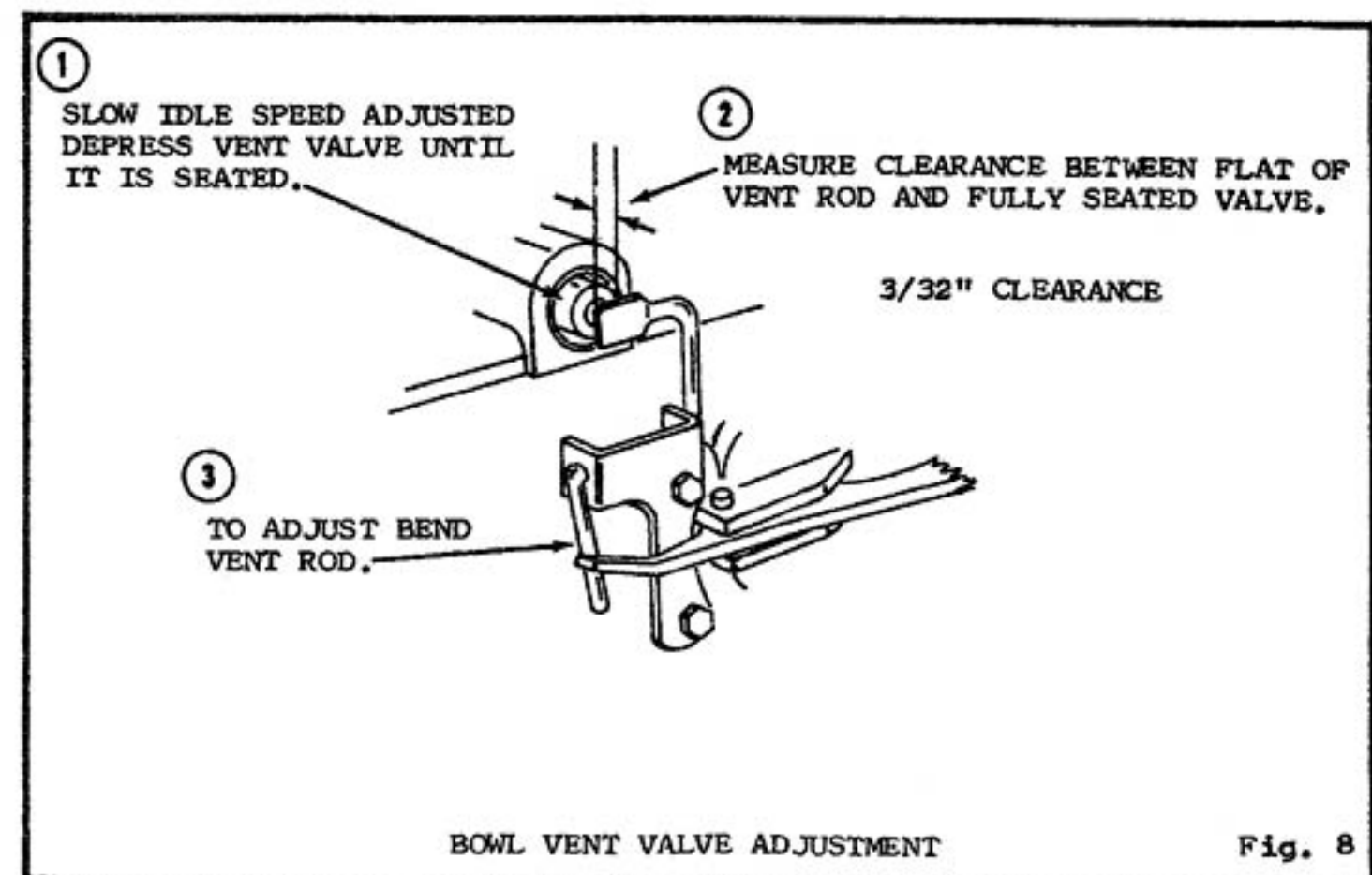
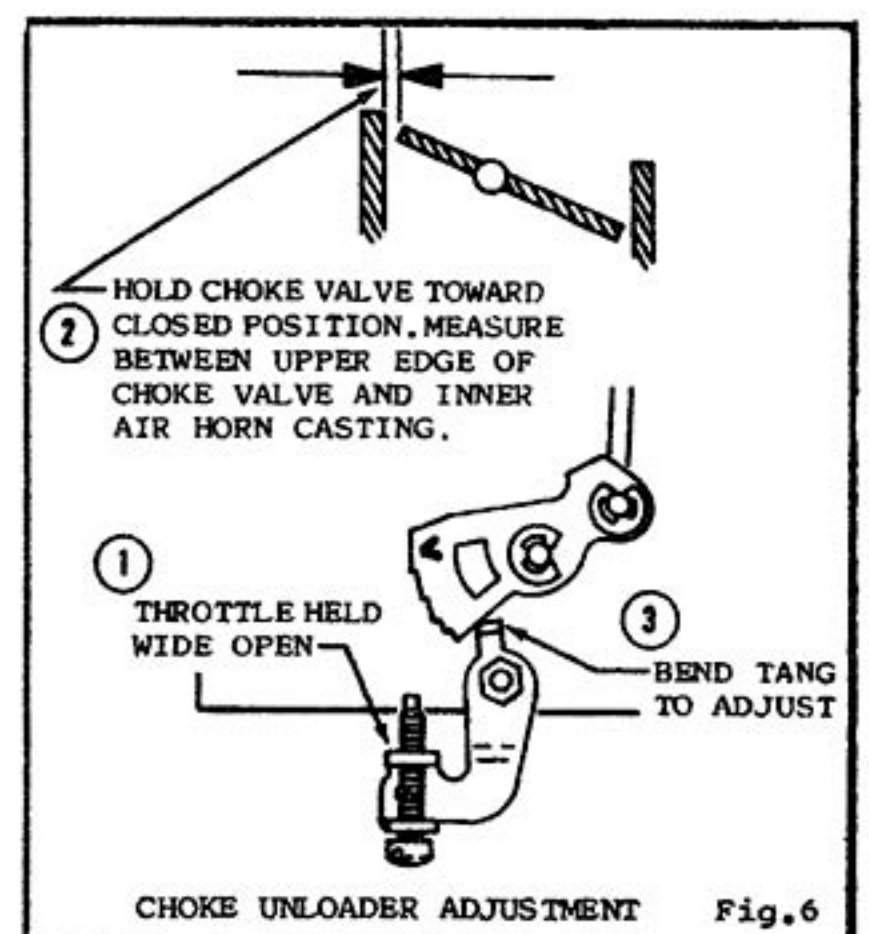
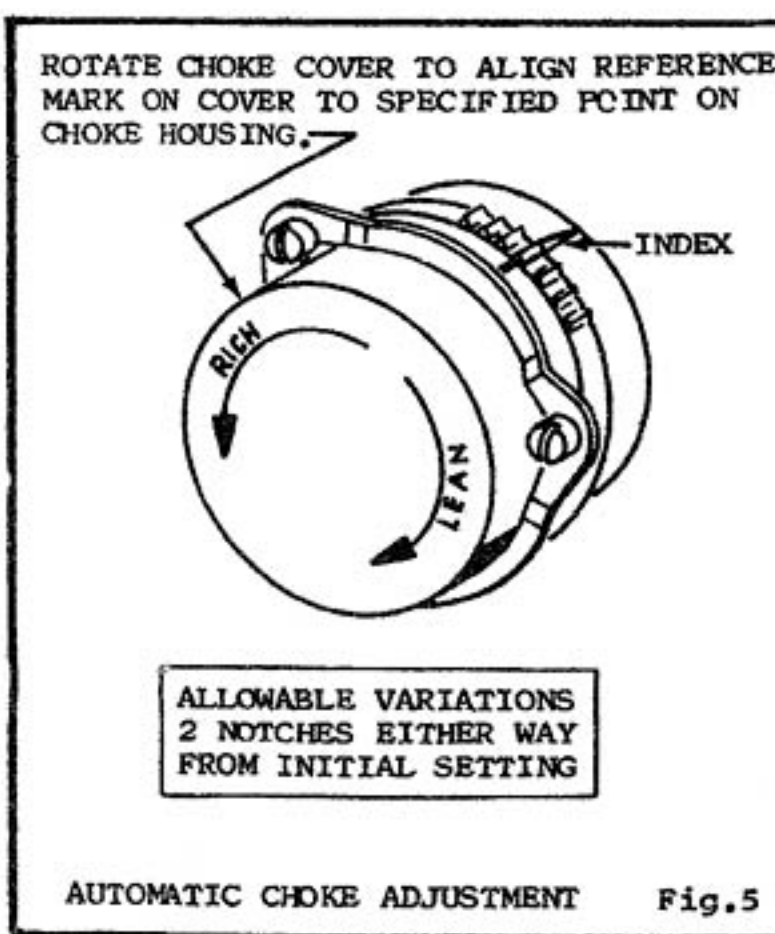
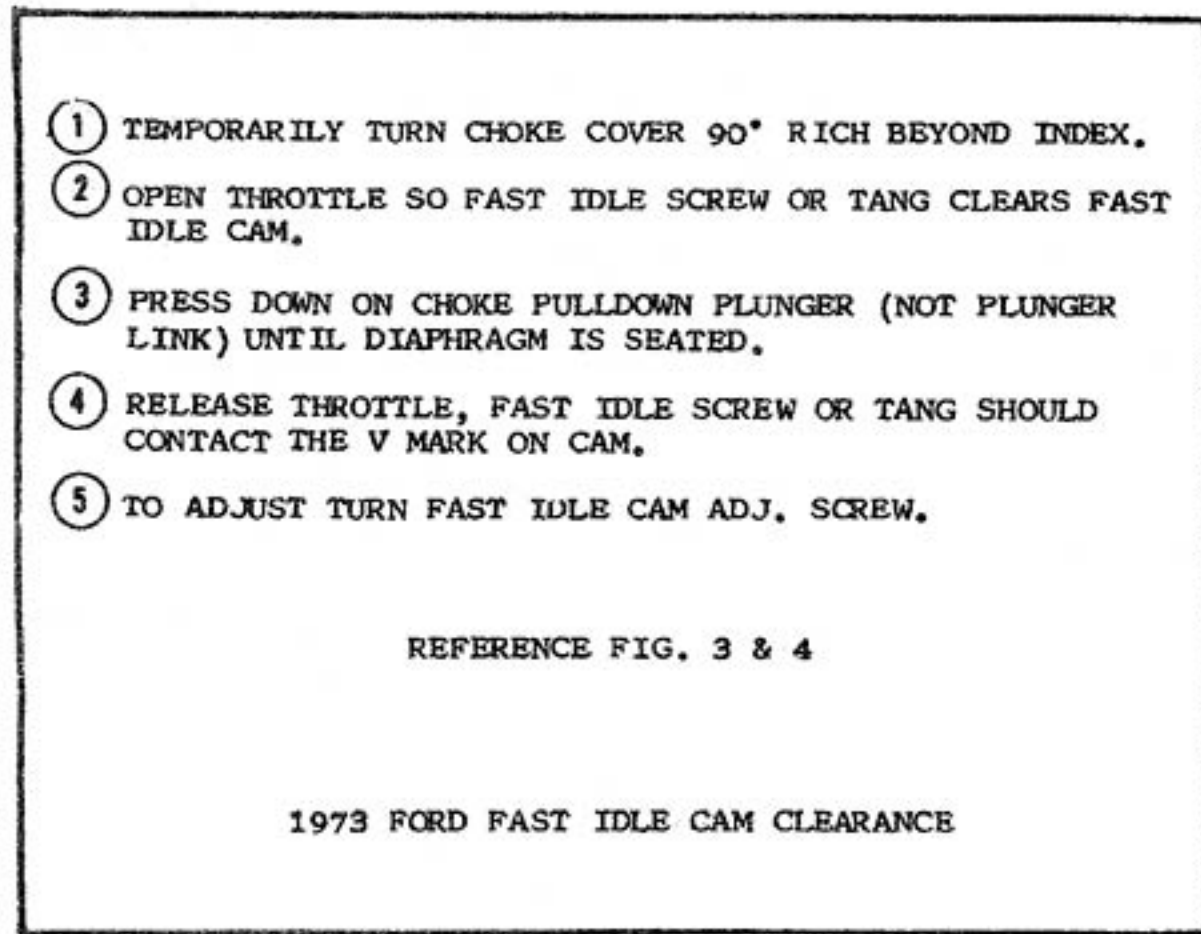
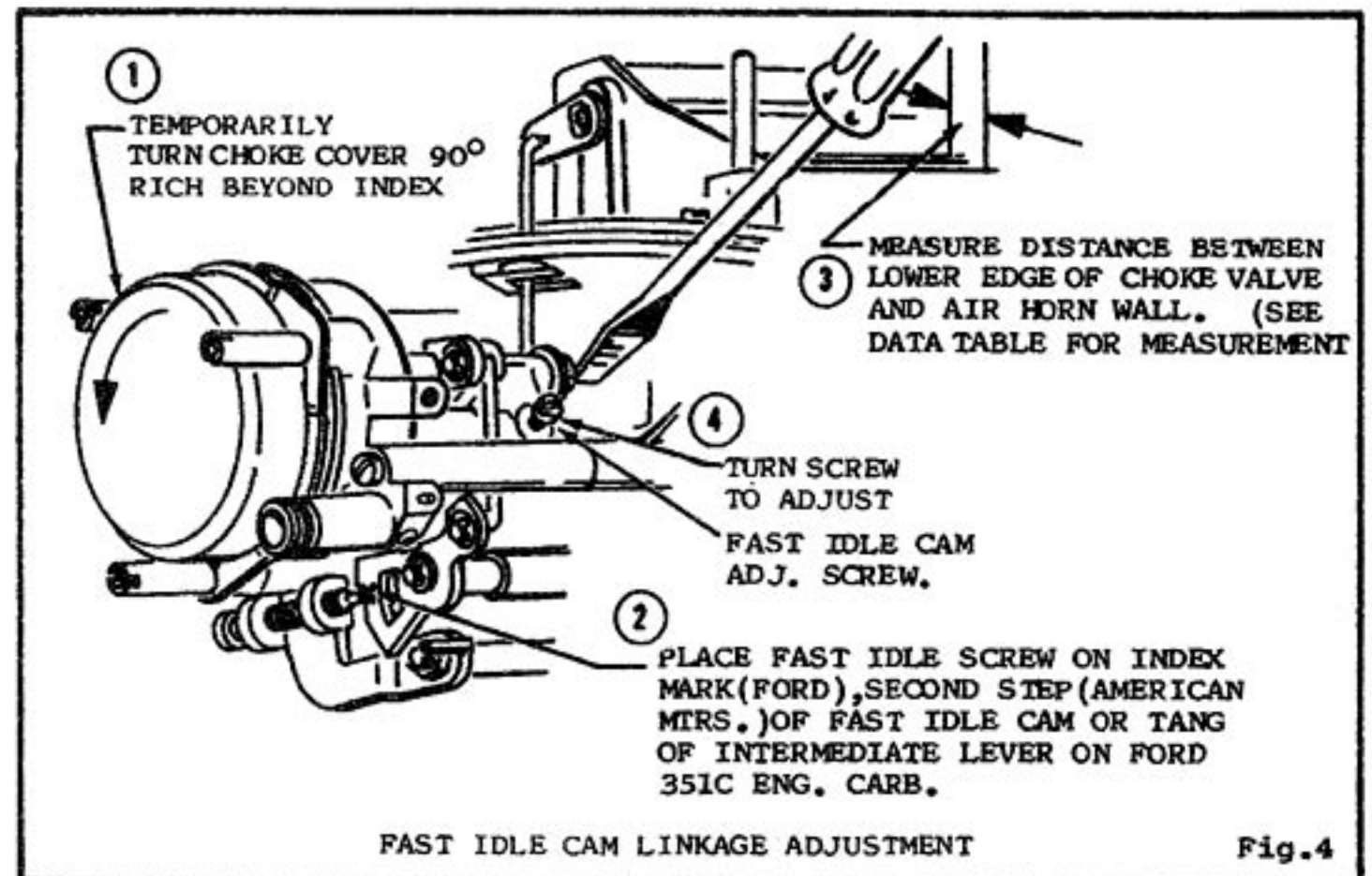
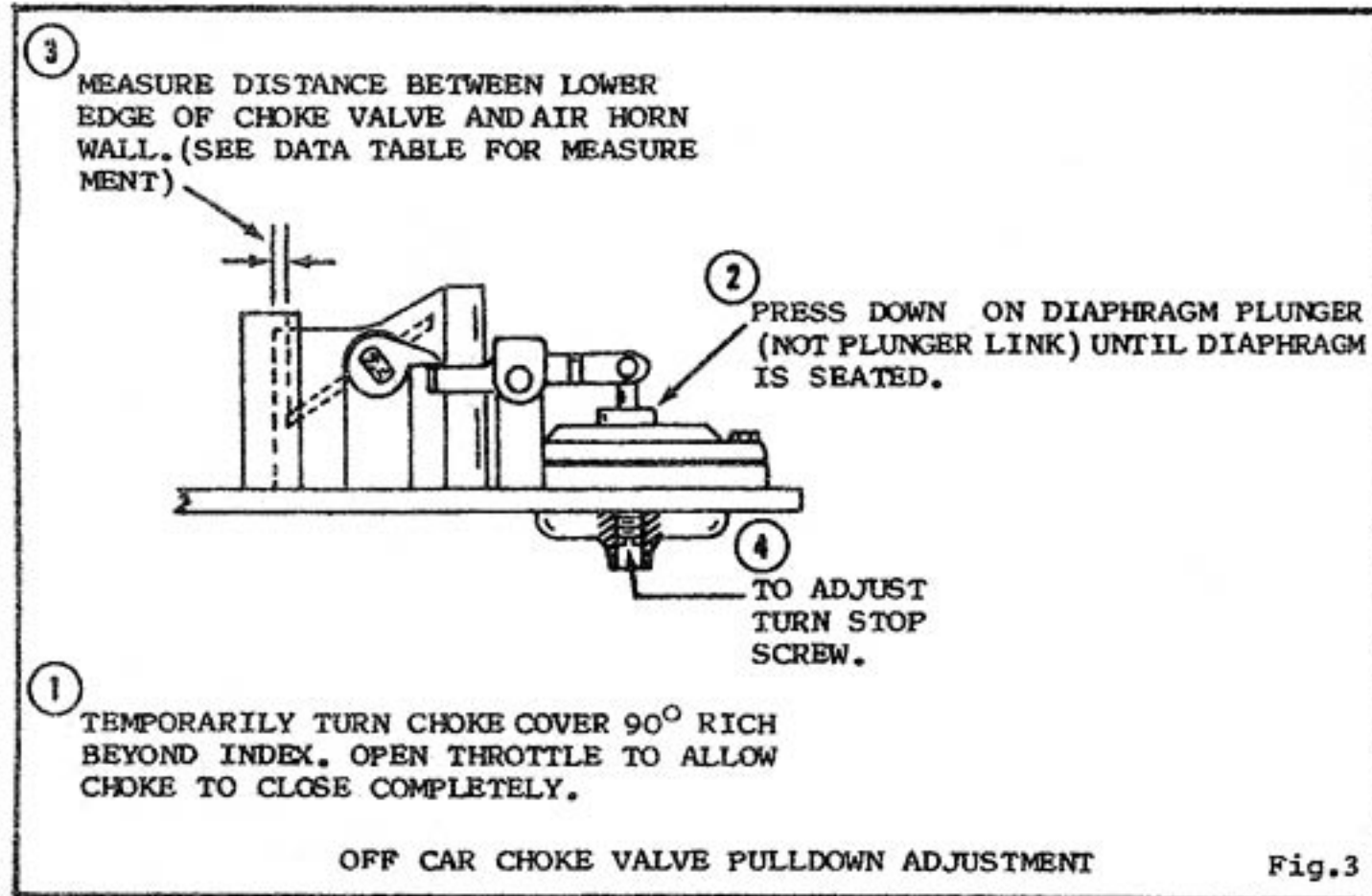
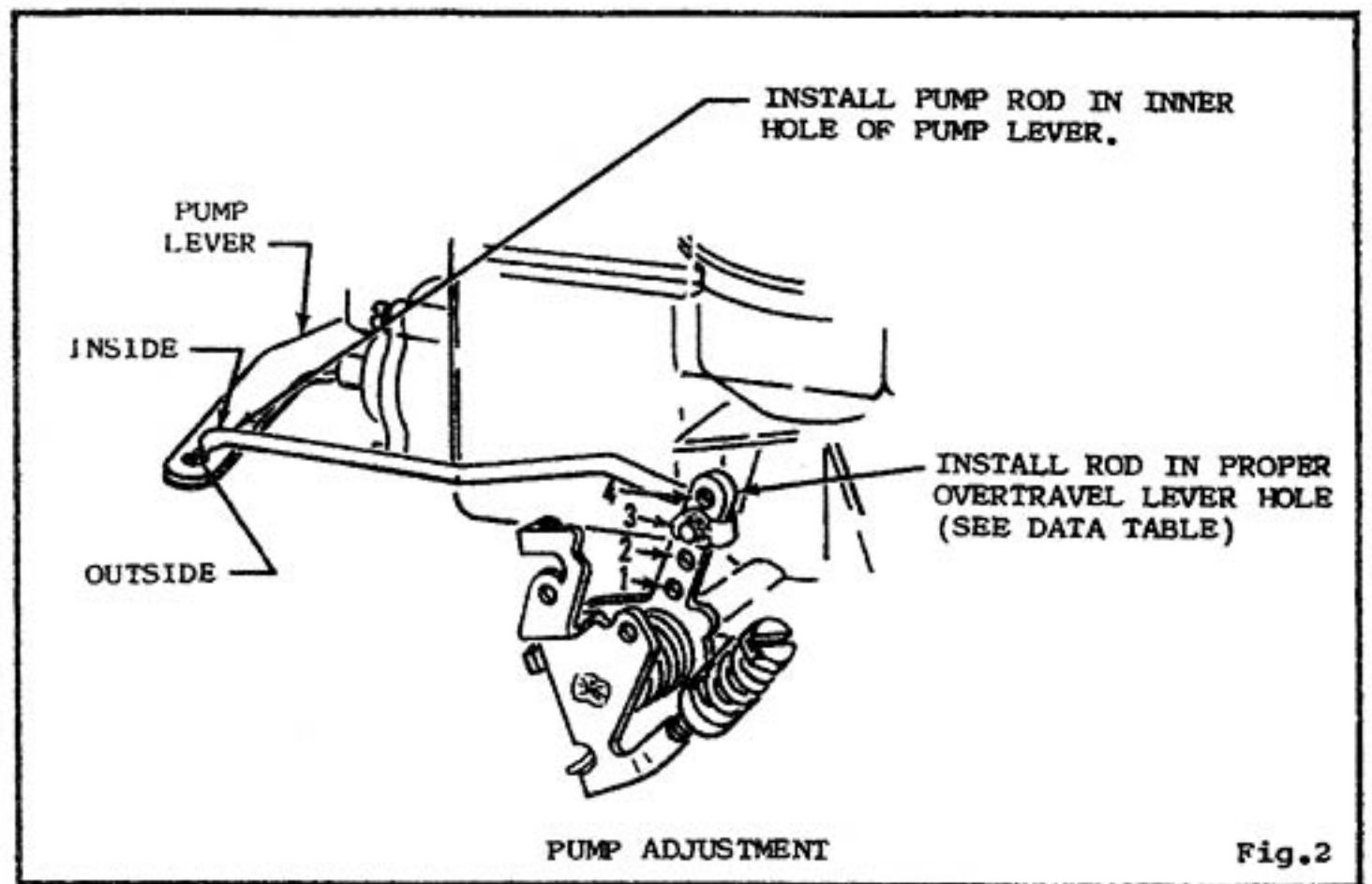
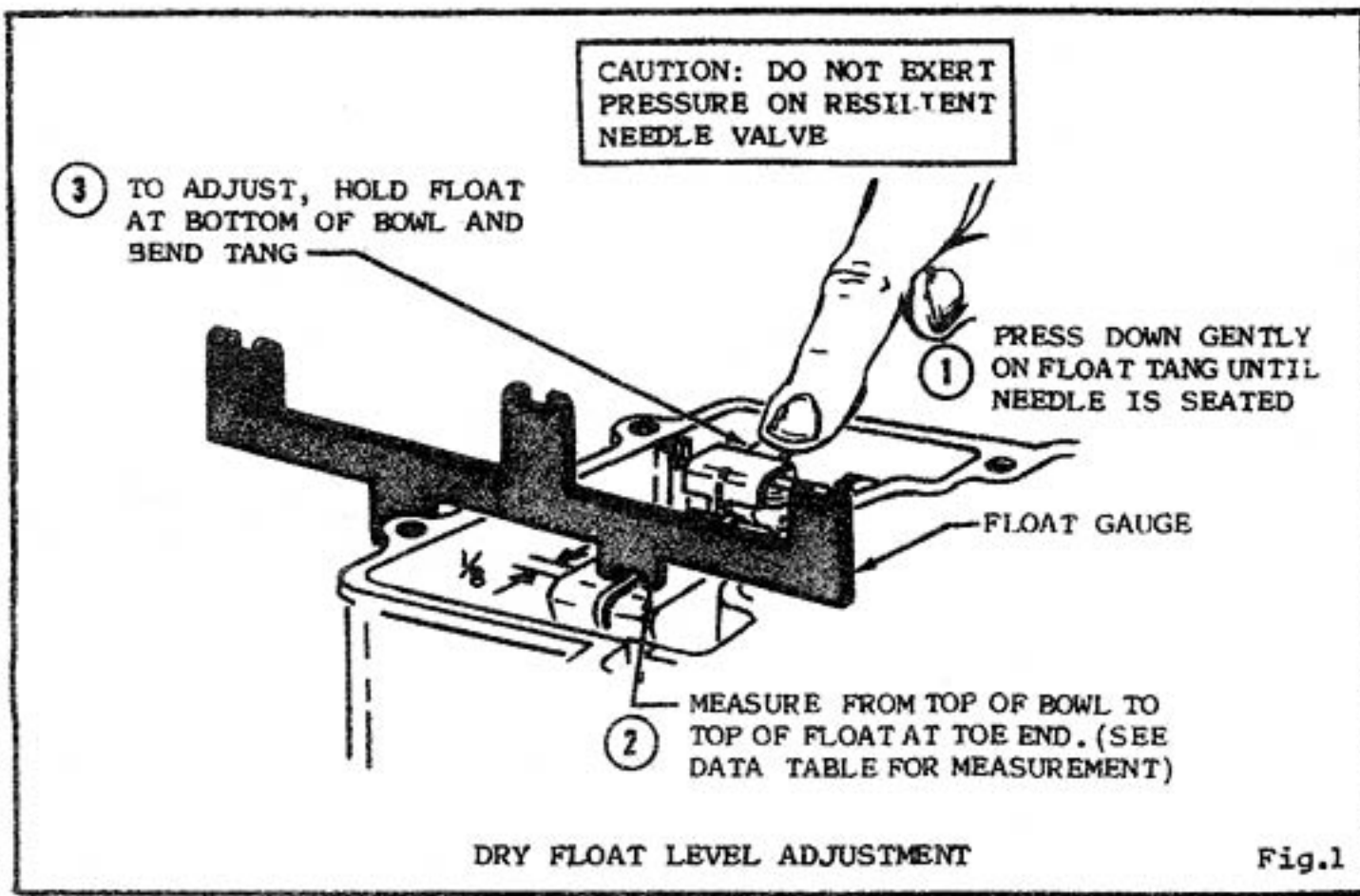

USE FACTORY CAR MANUAL PROCEDURE FOR SETTING SLOW IDLE IF IF AVAILABLE, AND SPECIFICATIONS LISTED ON ENGINE DECAL.

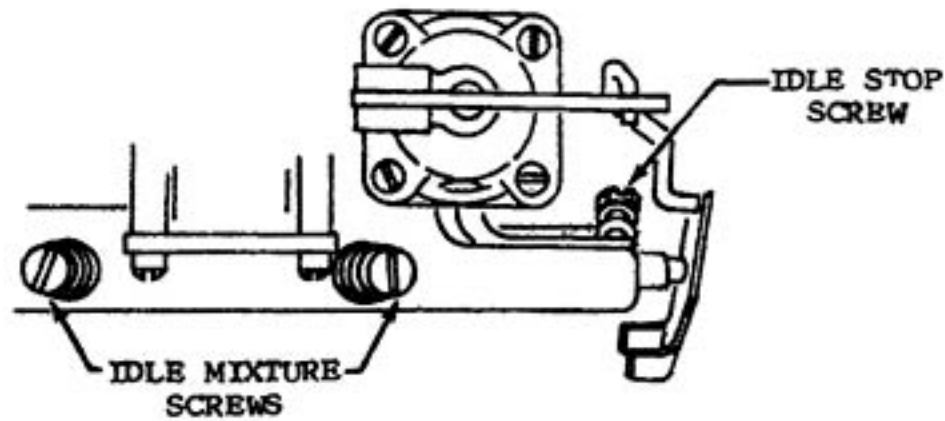

SUPPLEMENT

SLOW IDLE ADJUSTMENT PROCEDURE WITH AND WITHOUT THROTTLE SOLENOID POSITIONER.

1. SET IGNITION TIMING PER CAR FACTORY SPECIFICATIONS AND PROCEDURE.
2. ENGINE AT OPERATING TEMPERATURE, CHOKE FULLY OPEN.
 - A. AIR CLEANER INSTALLED
 - B. HEADLIGHTS ON HIGH BEAM.
 - C. AUTOMATIC TRANSMISSION IN DRIVE.
 - D. HOT IDLE COMPENSATOR VALVE CLOSED.
3. ADJUST THROTTLE STOP SCREW TO SPECIFIED IDLE SPEED R.P.M. USING A TACHOMETER.

NOTE: WHEN USED, ADJUST SOLENOID THROTTLE POSITIONER TO SPECIFIED IDLE SPEED (SOLENOID LEAD MUST BE CONNECTED SO SOLENOID WILL BE ENERGIZED.)
4. ADJUST IDLE MIXTURE NEEDLES TO OBTAIN THE HIGHEST R.P.M. AT THE LEANEST BEST IDLE SETTING.
5. READJUST IDLE SPEED IF NECESSARY.

NOTE: DISCONNECT SOLENOID THROTTLE POSITIONER AT BULLET CONNECTION THEN ADJUST THROTTLE STOP SCREW FOR LOWER R.P.M. WITH AUTOMATIC OR MANUAL TRANSMISSIONS IN NEUTRAL. CONNECT SOLENOID, OPEN THROTTLE AND RELEASE, RECHECK HIGHER IDLE SPEED.

SLOW IDLE ADJUSTMENT

Fig. 9

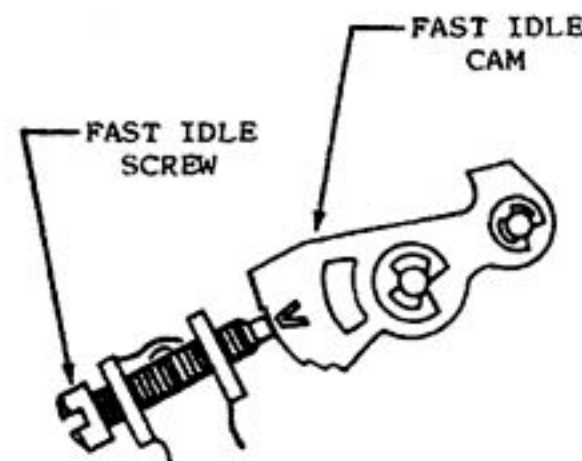

ADJUST SLOW IDLE, THEN PLACE FAST IDLE SCREW OR LEVER TANG ON SECOND STEP OF FAST IDLE CAM AND ADJUST FAST IDLE SCREW TO PROPER R.P.M.

NOTE: ELECTRONIC SPARK CONTROL OR TRANSMISSION REGULATED SPARK SYSTEM WITH AMBIENT TEMPERATURE ABOVE 55° F. CONNECT A VACUUM LINE DIRECTLY FROM CARBURETOR SPARK PORT TO ADVANCE SIDE OF DISTRIBUTOR (i.e. BY PASSING THE SPARK CONTROL SYSTEM.) DISCONNECT THE VACUUM SUPPLY LINE TO THE EGR VALVE AND PLUG THE LINE.

FAST IDLE ADJUSTMENT

Fig. 10

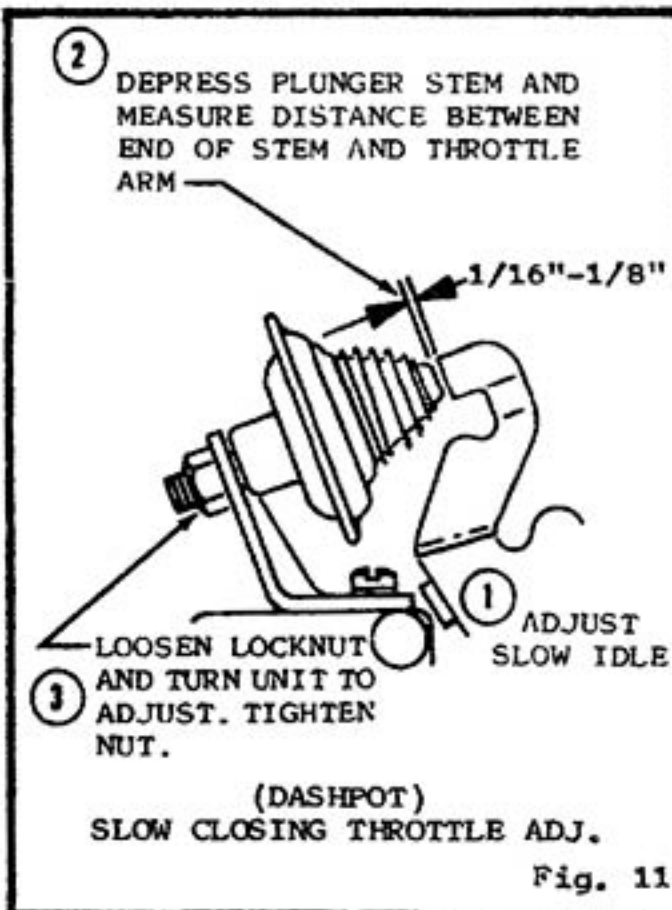

ADJUSTMENT DATA TABLE

Year	Make		Dry Float Level	Pump Overtravel Lever Hole	Choke Valve Pulldown	Fast Idle Cam Linkage Adj.	Automatic Choke Setting	Unloader	Slow Idle R. P. M. *	Fast Idle R. P. M.
Bronco, Comet, Cougar, Falcon, Fairlane, Ford Mercury, Montego, Mustang, Torino										
1970	302" Eng.	All/T	7/16"	No. 3	5/32"	1/8"	1 - RICH	1/16"	800/500 S/T 600/500 A/T	1500 1500
		A/T	7/16"	No. 4	13/64"	11/64"	2 - LEAN	---	600/500	1600
	351" W Eng.	S/T	7/16"	No. 3	15/64"	3/16"	2 - LEAN	---	800/500	1300
		A/T	7/16"	No. 3	3/16"	1/8"	1 - RICH	1/16"	600/500	1500
	351" C Eng.	S/T	7/16"	No. 4	7/32"	3/16"	INDEX	1/16"	700/500	1500
		A/T	7/16"	No. 3	13/64"	5/32"	2 - RICH	1/16"	600/500	1500
390" Eng.	S/T	7/16"	No. 3	7/32"	11/64"	1 - RICH	1/16"	750/500	1400	
	A/T	7/16"	No. 3	13/64"	5/32"	2 - RICH	1/16"	600/500	1400	
429" Eng.	A/T	7/16"	No. 3	13/64"	5/32"	2 - RICH	1/16"	600/500	1400	
Comet										
1971	302" Eng.	All/T	7/16"	No. 3	11/64"	5/32"	1 - RICH	1/16"	600/500 A/T 800/500 S/T	1400 1400
		All/T	7/16"	No. 3	13/64"	11/64"	1 - RICH	1/16"	600/500 A/T 800/500 S/T	1500 1500
351" C Eng.	A/T	7/16"	No. 3	3/16"	11/64"	1 - RICH	1/16"	600/500	1500	
	S/T	7/16"	No. 3	15/64"	3/16"	INDEX	1/16"	750/500	1500	
Carb. No. D1ZF-UA	A/T	7/16"	No. 3	11/64"	1/8"	1 - RICH	1/16"	625/500	1500	
Cougar										
1971	302" Eng.	All/T	7/16"	No. 3	11/64"	5/32"	1 - RICH	1/16"	600/500 A/T 800/500 S/T	1400 1400
		A/T	7/16"	No. 3	3/16"	11/64"	1 - RICH	1/16"	600/500	1500
351" C Eng.	S/T	7/16"	No. 3	15/64"	3/16"	INDEX	1/16"	750/500	1500	
	A/T	7/16"	No. 3	11/64"	1/8"	1 - RICH	1/16"	625/500	1500	
Ford										
1971	302" Eng.	A/T	7/16"	No. 3	11/64"	5/32"	1 - RICH	1/16"	600/500	1400
		S/T	7/16"	No. 2	5/32"	1/8"	INDEX	1/16"	800/500	1500
351" W Eng.	A/T	7/16"	No. 3	13/64"	5/32"	1 - RICH	1/16"	580	1500	
	S/T	7/16"	No. 3	7/32"	3/16"	1 - RICH	1/16"	600/500	1300	
W/AC	A/T	7/16"	No. 3	3/16"	1/8"	INDEX	1/16"	600/500	1600	
	A/T	7/16"	No. 3	13/64"	5/32"	INDEX	1/16"	600/500	1500	
390" Eng.	A/T	7/16"	No. 3	3/16"	5/32"	1 - RICH	1/16"	600/500	1500	
	A/T	7/16"	No. 3	13/64"	5/32"	1 - RICH	1/16"	590	1400	
400" Eng.	A/T	7/16"	No. 3	13/64"	5/32"	1 - RICH	1/16"	590	1400	
	A/T	7/16"	No. 3	13/64"	5/32"	1 - RICH	1/16"	590	1400	

Year	Make		Dry Floot Level	Pump Overtravel Lever Hole	Choke Valve Pulldown	Fast Idle Cam Linkage Adj.	Automatic Choke Setting	Unloader	Slow Idle R. P. M. *	Fast Idle R. P. M.
Mercury										
1971	351" W Eng.	A/T	7/16"	No. 3	3/16"	1/8"	INDEX	1/16"	575	1600
		S/T	7/16"	No. 3	7/32"	3/16"	1 - RICH	1/16"	600/500	1300
	W/AC 400" Eng.	A/T	7/16"	No. 3	3/16"	1/8"	INDEX	1/16"	600/500	1600
		A/T	7/16"	No. 3	3/16"	5/32"	1 - RICH	1/16"	600/500	1500
	Carb. No. D1ZF-UA D1OF-YA 429" Eng.	S/T	7/16"	No. 3	15/64"	13/64"	INDEX	1/16"	750/500	1500
		A/T	7/16"	No. 3	11/64"	1/8"	1 - RICH	1/16"	625/500	1500
A/T	7/16"	No. 3	13/64"	5/32"	1 - RICH	1/16"	590	1400		
Montego										
1971	302" Eng.	A/T	7/16"	No. 3	11/64"	5/32"	1 - RICH	1/16"	600/500	1400
		S/T	7/16"	No. 3	11/64"	5/32"	1 - RICH	1/16"	800/500	1400
	W/AC Carb. No. D1AF-BA 351" C Eng.	A/T	7/16"	No. 2	5/32"	1/8"	INDEX	1/16"	600/500	1500
		S/T	7/16"	No. 2	5/32"	1/8"	INDEX	1/16"	800/500	1500
	A/T	7/16"	No. 3	3/16"	11/64"	1 - RICH	1/16"	600/500	1500	
		S/T	7/16"	No. 3	15/64"	3/16"	INDEX	1/16"	750/500	1500
	A/T	7/16"	No. 3	11/64"	1/8"	1 - RICH	1/16"	625/500	1500	
Mustang - Torino										
1971	302" Eng.	A/T	7/16"	No. 3	11/64"	5/32"	1 - RICH	1/16"	600/500	1400
		S/T	7/16"	No. 2	5/32"	1/8"	INDEX	1/16"	800/500	1500
	W/AC 351" C Eng.	A/T	7/16"	No. 2	5/32"	1/8"	INDEX	1/16"	600/500	1500
		A/T	7/16"	No. 3	3/16"	11/64"	1 - RICH	1/16"	600/500	1500
	S/T	7/16"	No. 3	15/64"	3/16"	INDEX	1/16"	750/500	1500	
		A/T	7/16"	No. 3	11/64"	1/8"	1 - RICH	1/16"	625/500	1500
Comet, Cougar, Ford, Maverick, Mercury, Meteor, Montego, Mustang, Thunderbird, Torino										
1972	302" Eng.	A/T	7/16"	No. 2	5/32"	1/8"	1 - RICH	1/16"	600/500	1400
		S/T	7/16"	No. 2	9/64"	1/8"	1 - RICH	1/16"	800/500	1400
	351" W Eng.	A/T	7/16"	No. 3	9/64"	1/8"	INDEX	1/32"	600/500	1500
		A/T	7/16"	No. 3	3/16"	5/32"	1 - RICH	1/32"	600/500	1500
	S/T	7/16"	No. 3	15/64"	13/64"	1 - RICH	1/32"	750/500	1400	
		A/T	7/16"	No. 4	3/16"	5/32"	1 - RICH	1/16"	625/500	1500
1972	302" Eng.	A/T	7/16"	No. 2	9/64"	7/64"	1 - RICH	1/16"	600/500	1450
		A/T	7/16"	No. 2	9/64"	1/8"	2 - RICH	1/8"	600	1500
	Bronco 330" Eng.	S/T	7/16"	No. 2	9/64"	7/64"	1 - RICH	1/16"	800/500	1100
		S/T	7/16"	No. 4	11/64"	---	---	---	---	1200
	360" - 390" Eng.	A/T	7/16"	No. 4	5/32"	9/64"	1 - RICH	9/64"	550	1500
		S/T	1/2"	No. 4	5/32"	9/64"	2 - RICH	9/64"	650	1250
A/T	1/2"	No. 2	5/32"	5/32"	1 - LEAN	---	750/500	1200		
Comet, Cougar, Ford, Maverick, Mercury, Meteor, Montego, Mustang, Ranchero, Torino										
1973	302" Eng.	S/T	7/16"	No. 2	None	---	1 - RICH	---	E/D	1250
		A/T	7/16"	No. 2	None	---	3 - RICH	---	E/D	1400
	Carb. No. D3GF-AF D3OF-EA 351" C Eng.	A/T	7/16"	No. 2	None	---	1 - RICH	---	E/D	1400
		A/T	7/16"	No. 3	None	---	3 - RICH	---	E/D	1500
	A/T	7/16"	No. 2	5/32"	---	2 - RICH	---	E/D	1500	
		A/T	7/16"	No. 3	None	---	3 - RICH	---	E/D	1500
Comet, Cougar, Ford, Maverick, Mercury, Meteor, Montego, Mustang, Ranchero, Torino										
1974	302" Eng.	S/T	7/16"	No. 2	---	---	3 - RICH	---	E/D	---
		A/T	7/16"	No. 2	---	---	3 - RICH	---	E/D	---
	351" Eng.	A/T	7/16"	No. 2	---	---	3 - RICH	---	E/D	---
		A/T	7/16"	No. 2	---	---	1 - RICH	---	E/D	---
	400" Eng.	A/T	7/16"	No. 3	---	---	3 - RICH	---	E/D	---
		Ford Truck								
1973	302" Eng. Bronco	S/T	1/2"	No. 3	None	---	2 - RICH	---	E/D	1100
		A/T	1/2"	No. 2	None	---	2 - RICH	---	E/D	1500
	E - 300 Van & F100	S/T	7/16"	No. 3	None	7/64"	2 - RICH	---	E/D	1100
		A/T	7/16"	No. 2	None	7/64"	2 - RICH	---	E/D	1400
	Except E-300 Van	S/T	7/16"	No. 3	None	---	2 - RICH	---	E/D	1100
		A/T	7/16"	No. 2	None	---	2 - RICH	---	E/D	1500
	330" Eng.	S/T	7/16"	No. 4	11/64"	---	MANUAL	---	E/D	1200
		S/T	1/2"	No. 2	None	5/32"	INDEX	---	E/D	1200
	360" - 390" Eng. F100	A/T	7/16"	No. 4	None	1/8"	INDEX	---	E/D	1500
		S/T	1/2"	No. 4	None	1/8"	INDEX	---	E/D	1250
	A/T	7/16"	No. 4	None	1/8"	INDEX	---	E/D	1500	
	Ford Truck									
1974	302" Eng. Bronco F-100	All/T	1/2"	No. 3	---	---	3 - RICH	---	E/D	---
		S/T	7/16"	No. 3	---	---	2 - RICH	---	E/D	---
		A/T	7/16"	No. 3	---	---	2 - RICH	---	E/D	---
	Econoline	S/T	7/16"	No. 3	---	---	2 - RICH	---	E/D	---
		A/T	7/16"	No. 2	---	---	2 - RICH	---	E/D	---
	330" Eng. M/D	S/T	7/16"	No. 4	11/64"	---	MANUAL	---	E/D	---
		S/T	1/2"	No. 3	---	---	INDEX	---	E/D	---
	360" Eng. F-100	A/T	7/16"	No. 4	---	---	INDEX	---	E/D	---
		All/T	1/2"	No. 4	---	---	INDEX	---	E/D	---

* Note: Higher R. P. M. (Solenoid Energized)
Lower R. P. M. (Solenoid De - energized)

E/D = Engine Decal

Ford Motors
351" C Eng. - 12 Stud Manifold
351" W Eng. - 16 Stud Manifold